

Reactor



Shanghai JEGO Electric Co., Ltd

URL: <https://www.jegopower.com>

Address: No. 66 Xinlei Road, Xiangyang Industrial Zone, Liushi Town, Yueqing City, Zhejiang Province, China



Introduction

Dry-type iron-core series reactors are applied in low-voltage reactive power compensation cabinets in series with capacitors. When a large number of harmonic sources such as rectifiers and converters exist in the low-voltage power grid, the high-order harmonics generated will seriously endanger the safe operation of the main transformer and other electrical equipment.

When connected in series with capacitors, such reactors can effectively absorb grid harmonics, optimize the system voltage waveform, and improve the system power factor. They can also significantly suppress switching inrush currents and switching overvoltages, providing reliable protection for capacitors.

Special input and output reactors for frequency converters are generally installed at the input or output terminals of frequency converters and DC speed regulators. They can prevent harmonics generated by frequency converters from transmitting back to the power grid, reduce harmonic interference to other components, enhance power quality, raise the power factor, limit abnormal voltage fluctuations and surge currents in the grid, smooth voltage waveforms, and mitigate impacts on frequency converters.

When installed at the output side, these reactors limit the capacitive charging current of the connecting cables between frequency converters and motors, and slow down the voltage rise rate of the PWM waveform generated by frequency converters.

As one of the key components between frequency converters and motors, they effectively improve the power factor and compensation performance, optimize power quality and smooth electrical waveforms.

Knowledge on the application of reactors

1. Selection of Reactance Rate

The selection of reactance rate is rather complicated, because power harmonics themselves are unstable: their magnitude and frequency both change continuously. A properly selected reactance rate that suppresses a certain order of harmonics may amplify other orders of harmonics. Generally speaking, for the 3rd harmonic, a reactance rate of 12%–14% is mostly adopted; for the 5th harmonic, a reactance rate of 4.5%–7% is commonly used. Practical experience shows that a slightly higher reactance rate is beneficial to safe operation.

2. Wiring Mode

2.1 Wiring of Series Reactors

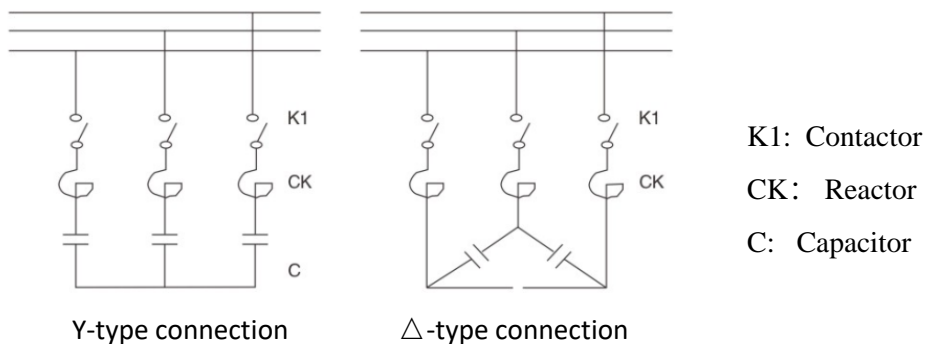

2.2 Wiring of Incoming and Outgoing Line Reactors

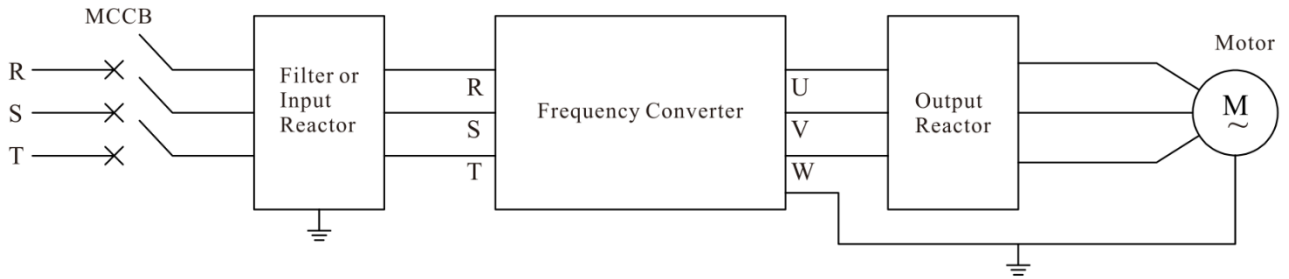

3 Technical Parameters

3.1 Series Reactor

- Applicable to 400V and 660V systems.
- Reactance rate types: 1%, 6%, 7%, 12%, 13%, 14%;
- Rated insulation level: 3kV/min.
- Temperature rise limits for each part of the reactor: core not exceeding 85K, coil temperature rise not exceeding 95K.
- The reactor can operate for a long time under power frequency plus harmonic current not greater than 1.35 times the rated current.
- The reactance difference between any two phases of a three-phase reactor is no more than $\pm 3\%$, and the heat resistance grade is above Class HF (180°C).

3.2 Inlet and Outlet Reactor

- Rated operating voltage: 380V/440V 50Hz
- Rated operating current: 5A to 1600A @ 40°C
- Dielectric strength: core-winding 3000VAC/50Hz/5mA/10s, no arc breakdown (factory test)
Insulation resistance: insulation resistance $\geq 100M\Omega$ at 1000VDC; reactor noise: less than 65dB (tested at 1 meter horizontal distance from the reactor);
- Protection grade: IP00; insulation grade: Class F or above.

FACL/FOCL Series Incoming/outgoing line reactor

During operation, frequency converters and speed regulators are often subjected to surges of inrush current and voltage, which can severely damage their performance and service life. An input reactor should be installed at their front end to suppress surge voltage and inrush current, protect the frequency converters and speed regulators, extend their service life, and prevent harmonic interference.



Meanwhile, as frequency converters and speed regulators adjust speed through frequency conversion, they frequently generate high-order harmonics and waveform distortion during speed regulation, which can affect the normal operation of equipment. An output reactor shall be installed at the output terminal to filter out harmonic voltage and harmonic current and improve power grid quality.

This reactor can be used with frequency converters of domestic and foreign brands such as Siemens, ABB, Hitachi, Toshiba, Panasonic, Yaskawa, Powtran, Danfoss, Fuji, Eurotherm, LG, Omron, Schneider Electric, Lenze, Emerson, and CONVO.

FACL Series Incoming line reactor

Governor inverter power kW	Input reactor Model	Rated current A	Overall dimensions Length×Width×Height mm	Mounting dimensions mm	Pressure drop	Inductance mH	Insulation class
2.2	FACL-10A	10	155×130×130	120×60-Φ8	2%	1.401	H
5.5	FACL-15A	15	155×130×130	120×60-48	2%	0.934	H
7.5	FACL-20A	20	155×130×130	120×60-48	2%	0.701	H
11	FACL-30A	30	155×130×130	120×60-Φ8	2%	0.467	H
15	FACL-40A	40	155×140×130	120×70-Φ8	2%	0350	H
18	FACL-50A	50	155×150×130	120×80-Φ8	2%	0.280	H
22	FACL-60A	60	155×150×130	120×80-Φ8	2%	0.234	H
30	FACL-80A	80	190×150×160	150×85-48	2%	0.175	H
37	FACL-90A	90	190×150×160	150×85-48	2%	0.156	H
45	FACL-120A	120	190×160×160	150×95-48	2%	0.117	H
55	FACL-150A	150	230×150×220	180×85-Φ8	2%	0.093	H
75	FACL-200A	200	230×150×220	180×85-Φ8	2%	0.070	H
93-110	FACL-250A	250	230×160×220	180×95-Φ8	2%	0.056	H
132	FACL-290A	290	265×180×250	200×90-Φ8	2%	0.048	H
160	FACL-330A	330	265×190×250	200×100-Φ8	2%	0.042	H
185	FACL-390A	390	265×190×250	200×100-Φ8	2%	0.036	H
220	FACL-490A	490	290×160×310	200×100-Φ8	2%	0.029	H
240	FACL-530A	530	290×160×310	200×100-Φ8	2%	0.026	H
280	FACL-600A	600	290×170×310	200×110-Φ8	2%	0.023	H
300	FACL-660A	660	290×170×310	200×110-Φ8	2%	0.021	H
380	FACL-800A	800	290×190×310	200×130-Φ8	2%	0.018	H
450	FACL-1000A	1000	360×270×420	200×190-Φ8	2%	0.014	H

FOCL Series outgoing line reactor

Governor inverter power kW	Ouput reactor Model	Rated current A	Overall dimensions Length×Width×Height mm	Mounting dimensions mm	Pressure drop	Inductance mH	Insulation class
2.2	FOCL-10A	10	155×130×130	120×60-Φ8	1%	0.701	H
5.5	FOCL-15A	15	155×130×130	120×60-Φ8	1%	0.467	H
7.5	FOCL-20A	20	155×130×130	120×60-Φ8	1%	0.350	H
11	FOCL-30A	30	155x130x130	120×60-48	1%	0.234	H
15	FOCL-40A	40	155×140×130	120×70-Φ8	1%	0.175	H
18	FOCL-50A	50	155×150×130	120×80-Φ8	1%	0.140	H
22	FOCL-60A	60	155×150×130	120×80-Φ8	1%	0.117	H
30	FOCL-80A	80	190x150x160	150×85-Φ8	1%	0.088	H
37	FOCL-90A	90	190×150×160	150×85-48	1%	0.078	H
45	FOCL-120A	120	190×160×160	150×95-Φ8	1%	0.058	H
55	FOCL-150A	150	230×150×220	180×85-Φ8	1%	0.047	H
75	FOCL-200A	200	230×150×220	180×85-Φ8	1%	0.035	H
93-110	FOCL-250A	250	230×160×220	180×95-Φ8	1%	0.028	H
132	FOCL-290A	290	265×180×250	200×90-Φ8	1%	0.024	H
160	FOCL-330A	330	265×190×250	200×100-Φ8	1%	0.021	H
185	FOCL-390A	390	265×190×250	200×100-Φ8	1%	0.018	H
220	FOCL-490A	490	290×160×310	200×100-Φ8	1%	0.014	H
240	FOCL-530A	530	290×160×310	200×100-Φ8	1%	0.013	H
280	FOCL-600A	600	290×170×310	200×110-48	1%	0.012	H
300	FOCL-660A	660	290×170×310	200×110-Φ8	1%	0.011	H
380	FOCL-800A	800	290×190×310	200×130-Φ8	1%	0.009	H
450	FOCL-1000A	1000	360×270×420	200×190-Φ8	1%	0.007	H

Note: The above specifications are common ones for reference only, and customization is available according to customer requirements.