

Reactor



Shanghai JEGO Electric Co., Ltd

URL: <https://www.jegopower.com>

Address: No. 66 Xinlei Road, Xiangyang Industrial Zone, Liushi Town, Yueqing City, Zhejiang Province, China



Introduction

Dry-type iron-core series reactors are applied in low-voltage reactive power compensation cabinets in series with capacitors. When a large number of harmonic sources such as rectifiers and converters exist in the low-voltage power grid, the high-order harmonics generated will seriously endanger the safe operation of the main transformer and other electrical equipment.

When connected in series with capacitors, such reactors can effectively absorb grid harmonics, optimize the system voltage waveform, and improve the system power factor. They can also significantly suppress switching inrush currents and switching overvoltages, providing reliable protection for capacitors.

Special input and output reactors for frequency converters are generally installed at the input or output terminals of frequency converters and DC speed regulators. They can prevent harmonics generated by frequency converters from transmitting back to the power grid, reduce harmonic interference to other components, enhance power quality, raise the power factor, limit abnormal voltage fluctuations and surge currents in the grid, smooth voltage waveforms, and mitigate impacts on frequency converters.

When installed at the output side, these reactors limit the capacitive charging current of the connecting cables between frequency converters and motors, and slow down the voltage rise rate of the PWM waveform generated by frequency converters.

As one of the key components between frequency converters and motors, they effectively improve the power factor and compensation performance, optimize power quality and smooth electrical waveforms.

Knowledge on the application of reactors

1. Selection of Reactance Rate

The selection of reactance rate is rather complicated, because power harmonics themselves are unstable: their magnitude and frequency both change continuously. A properly selected reactance rate that suppresses a certain order of harmonics may amplify other orders of harmonics. Generally speaking, for the 3rd harmonic, a reactance rate of 12%–14% is mostly adopted; for the 5th harmonic, a reactance rate of 4.5%–7% is commonly used. Practical experience shows that a slightly higher reactance rate is beneficial to safe operation.

2. Wiring Mode

2.1 Wiring of Series Reactors

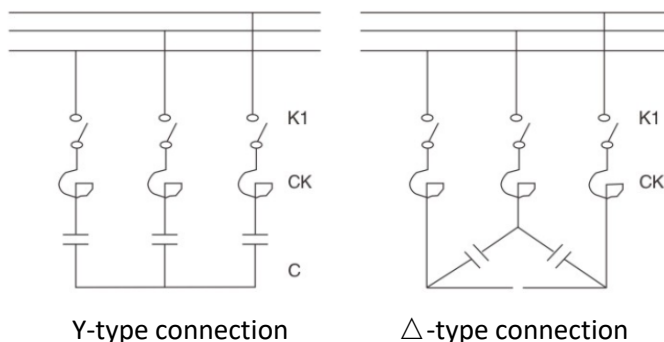

K1: Contactor
 CK: Reactor
 C: Capacitor

2.2 Wiring of Incoming and Outgoing Line Reactors

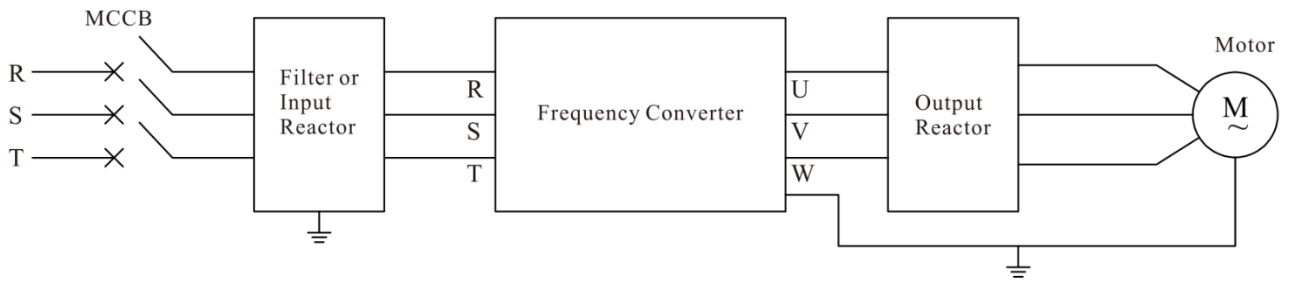

3 Technical Parameters

3.1 Series Reactor

- Applicable to 400V and 660V systems.
- Reactance rate types: 1%, 6%, 7%, 12%, 13%, 14%;
- Rated insulation level: 3kV/min.
- Temperature rise limits for each part of the reactor: core not exceeding 85K, coil temperature rise not exceeding 95K.
- The reactor can operate for a long time under power frequency plus harmonic current not greater than 1.35 times the rated current.
- The reactance difference between any two phases of a three-phase reactor is no more than $\pm 3\%$, and the heat resistance grade is above Class HF (180°C).

3.2 Inlet and Outlet Reactor

- Rated operating voltage: 380V/440V 50Hz
- Rated operating current: 5A to 1600A @ 40°C
- Dielectric strength: core-winding 3000VAC/50Hz/5mA/10s, no arc breakdown (factory test)
Insulation resistance: insulation resistance $\geq 100M\Omega$ at 1000VDC; reactor noise: less than 65dB (tested at 1 meter horizontal distance from the reactor);
- Protection grade: IP00; insulation grade: Class F or above.

DCL Series DC Reactors



DCL series DC reactors (also known as DC smoothing reactors) are mainly installed on the DC side of converters and frequency inverters, with the core functions as follows:

Smoothing and filtering: Suppress the ripple on the DC bus, maintain continuous rectifier current, reduce current pulsation, and ensure more stable operation of the inverter stage.

Power quality improvement: Improve the input power factor, reduce current waveform distortion caused by capacitor filtering, and decrease harmonic pollution.

Component protection: Prevent impact current damage to rectifier bridges, avoid overheating of DC support capacitors, and extend service life.

Special applications: Limit circulating current in parallel frequency inverter DC bus systems; restrict the current rise rate during fault current interruption by DC quick breakers; serve as the smoothing reactor in the intermediate circuit of current-source or voltage-source inverters.

Industrial adaptation: Suitable for harsh power grid environments in mining, metallurgy, textile and other industries to ensure stable operation of high-power equipment.

The product features low loss, good heat dissipation, strong anti-interference performance and high insulation class, ideal for long-term continuous operation in power electronic devices such as frequency inverters and rectifiers.

Type	Rated Current A	Voltage Drop V	Rated inductance mH	Overall dimensions mm			installation dimensions mm		mounting hole size mm
				L	W	H	L1	W1	
DCL-10	10	9	2.87	95	95	110	85	75	8*13
DCL-15	15	9	1.91	95	95	110	85	75	8*13
DCL-20	20	10	1.59	120	110	150	75	85	8*20
DCL-30	30	10	1.06	120	110	150	75	85	8*20
DCL-40	40	10	0.796	160	130	175	65	70	11*24
DCL-50	50	10	0.637	160	130	175	65	70	11*24
DCL-60	60	10	0.53	160	130	180	65	70	11*24
DCL-80	80	8	0.318	170	130	170	65	85	11*24
DCL-110	110	8	0.232	145	125	170	65	90	11*24
DCL-125	125	8	0.204	150	135	170	65	90	11*24
DCL-150	150	10	0.212	180	175	215	70	115	11*24
DCL-200	200	8	0.127	180	175	220	70	115	11*24
DCL-250	250	8.5	0.108	180	185	260	70	115	11*24
DCL-300	300	10	0.106	185	180	265	70	115	11*24
DCL-400	400	10	0.0796	190	195	265	70	115	11*24
DCL-500	500	10	0.064	210	205	290	90	130	11*24
DCL-600	600	10	0.053	210	215	290	90	135	11*24